

Defensive Principles & Rules 91-92

Principles

Contain the Dribbler

- A. Force to the corner
- B. No ball reversal

2. Help & Rotate Position

- A. Red Line Theory
- B. Rotate to **HELP, SWITCH, OR TRAP**
- C. Match up on men on **BALLSIDE** of Red Line Theory

3. Rebounding

- A. Look to your man
- B. Move your Feet

Lane Defense to FULL front

High - Side - High

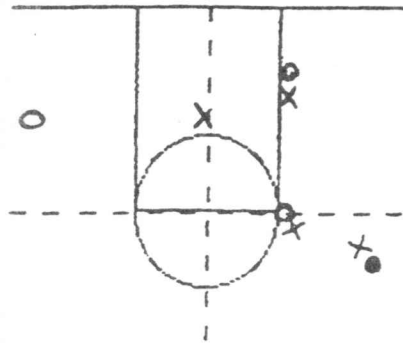

Green Line Theory

Ball Above

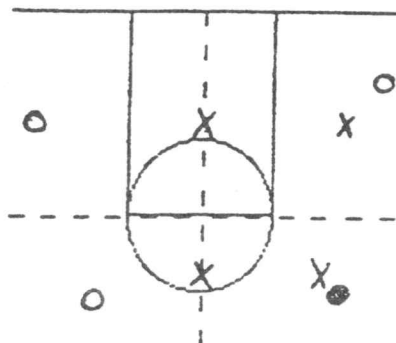

Shooting Area's

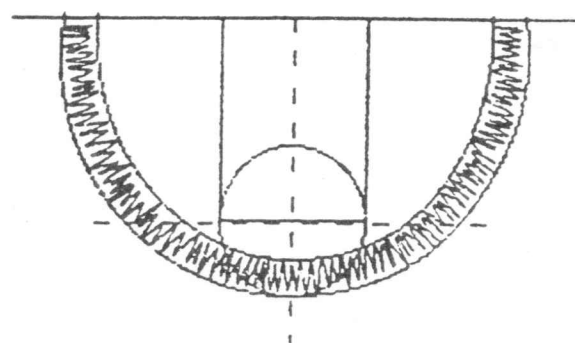

Low - Side - Low

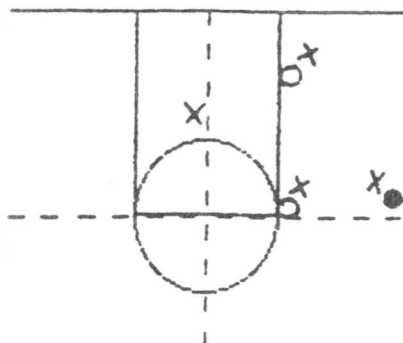

Ball Below



No Man's Land

